

LOW DISTORTION LINE MATCHING TRANSFORMER

P3356

Features

- * Lead-free (Pb-free)
- * RoHS compliant
- * Low Distortion
- * 12.6mm (0.5") Seated Height
- * Industry Standard Pinout
- * IEC 60950 and UL 60950 Certified
- * UL Recognized Component
- * Demko certified to EN 60950
- * Environmentally tested to IEC 68
- * CERT reliability tested
- * Excellent Frequency Response
- * Simple Matching
- * High Thermal Stability

Applications

- * V.90 and V.92 Modems
- * V.34 Modems
- * Fax Machines
- * Instrumentation

DESCRIPTION

P3356 is intended for V.90 and V.92 (56kbps) modems and other high-speed applications where ultra-low distortion at moderate power levels and very low voiceband frequencies is required at a most competitive price.

P3356 uses patented design and construction methods to achieve excellent signal performance and safety isolation to international standards, making it the component of choice for high-speed data applications throughout the world. P3356 is certified to IEC 60950, UL 60950 and EN 60950. P3356 is a UL Recognized Component, and is supported by IEC CB and Demko Certificates. The part is completely lead-free, compliant with RoHS Directive 2002/95/EC, and suitable for lead-free and conventional processing.

P3356 has exceptionally flat frequency response from 30Hz to 10kHz, a 3dB bandwidth of over 50kHz and requires only the very simplest of matching to achieve good return loss and transhybrid loss across the voiceband, with very low levels of signal distortion at signal frequencies as low as 150Hz.

P3356 is a rugged lightweight design that exhibits stable characteristics over its full operating temperature range to maximize data throughput under varying environmental conditions without the need for modem retraining.

P3356 has been subjected to relevant environmental testing according to IEC 68 and Combined Environmental Reliability Testing (CERT) beyond normal operational levels and passed all tests, remaining fully functional.

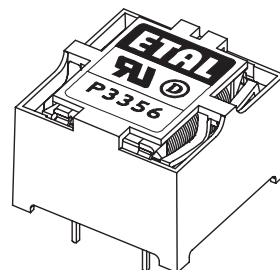

Patented



SPECIFICATIONS

Electrical

At T = 25°C and as circuit Fig. 2 unless otherwise stated.

Parameter	Conditions	Min	Typ	Max	Units
Insertion Loss	f = 2kHz, R _L = 600Ω	-	1.5	-	dB
Frequency Response	LF -3dB cutoff	-	10	-	Hz
	HF -3dB cutoff	-	55	-	kHz
	100Hz – 4kHz	-	-	±0.1	dB
Return Loss ⁽⁵⁾	200Hz – 4kHz	16	-	-	dB
Transhybrid Loss ⁽⁵⁾	200Hz – 4kHz	20	-	-	dB
Third Harmonic Distortion ⁽¹⁾	150Hz -3dBm in line	-	-70	-	dBm
	200Hz -10dBm in line	-	-89	-	dBm
Voltage Isolation ⁽²⁾	50Hz	2.12	-	-	kVrms
	DC	3.0	-	-	kV
Operating Range:	Functional	0	-	+70	°C
	Storage	-40	-	+85	°C

Lumped equivalent circuit parameters as Fig. 1

DC resistance ⁽³⁾	Primary resistance R _{DCp}	70	-	87	Ω
	Secondary resistance R _{DCs}	95	-	120	Ω
Leakage inductance, ΔL		3	3.9	5	mH
Shunt inductance, L _p ⁽⁴⁾	200Hz, 10mV	6	9	-	H
Shunt loss, R _p	200Hz, 10mV	12	15	-	kΩ

Notes:

1. Third harmonic typically exceeds other harmonics by 10dB.
2. Components are 100% tested at 3.25kVDC.
3. Caution: do not pass DC through windings. Telephone line current must be diverted using semiconductor line hold circuit or choke.
4. At signal levels greater than 100mV, L_p will increase and R_p will decrease slightly but the effect is usually favourable to the return loss characteristic.
5. Return loss and transhybrid loss can be improved to 30dB in improved matching circuit. The values shown relate to the simplest configuration, Fig. 2.

Equivalent Circuit

Fig. 1

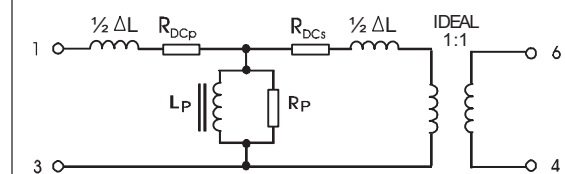

MATCHING RECOMMENDATIONS

The following recommendations start with the simplest implementations and progress to enhanced performance utilizing additional components. Good performance is achieved even with the simplest configurations. The implementations assume a low impedance balanced TX drive and a relatively high impedance RX input, as is commonly available, though use with other TX/RX arrangements is straightforward. Note that there are no changes to components on the line side, or in the hybrid, whether 600Ω or complex reference impedance selected, thus assisting country configuration. For complex impedance, the matching circuits derived are suitable for reference impedances of the type $270 + 750//150nF$ e.g. European CTR21 and $220 + 820//120nF$ (or $115nF$) e.g. Australia, South Africa, etc., and yield similar performance characteristics. For other impedances, please contact Profec Technologies.

Minimum Cost Implementations

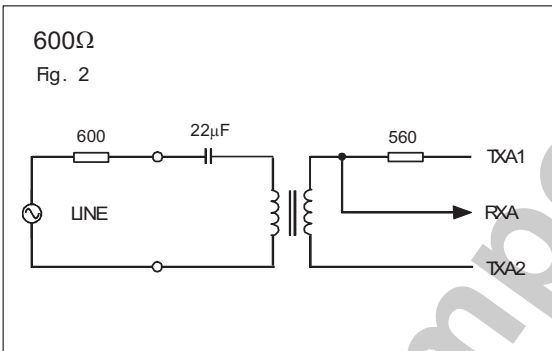

Insertion Loss: 1.8dB @ 2kHz
Frequency Response : $\pm 0.2dB$ 30Hz – 10kHz
Return Loss: 16dB 200Hz – 4kHz
Transhybrid Loss: 22dB 200Hz – 4kHz

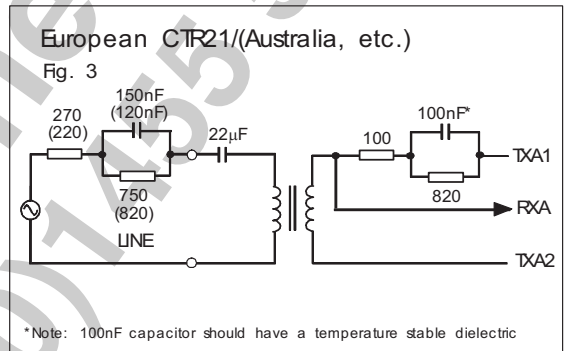

Insertion Loss: 1.0dB @ 2kHz
Frequency Response : $\pm 0.5dB$ 50Hz – 4kHz
Return Loss: 18dB 200Hz – 4kHz
Transhybrid Loss: 14dB 200Hz – 4kHz

*Note: 100nF capacitor should have a temperature stable dielectric

Improved matching

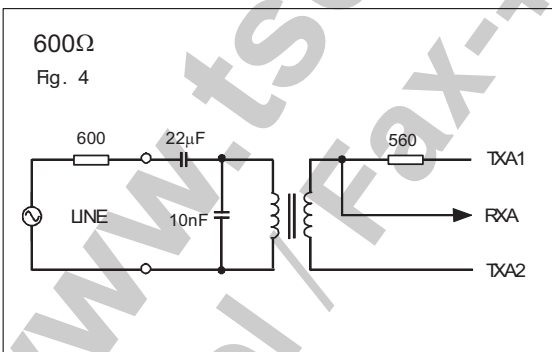

Insertion Loss: 1.8dB @ 2kHz
Frequency Response : $\pm 0.2dB$ 30Hz – 10kHz
Return Loss: 18dB 200Hz – 4kHz
Transhybrid Loss: 22dB 50Hz – 10kHz

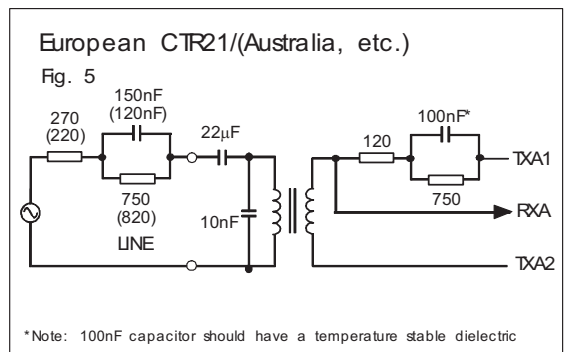

Insertion Loss: 1.0dB @ 2kHz
Frequency Response : $\pm 0.5dB$ 50Hz – 4kHz
Return Loss: 20dB 200Hz – 4kHz
Transhybrid Loss: 16dB 50Hz – 4kHz

*Note: 100nF capacitor should have a temperature stable dielectric

Patented

Improved matching and hybrid

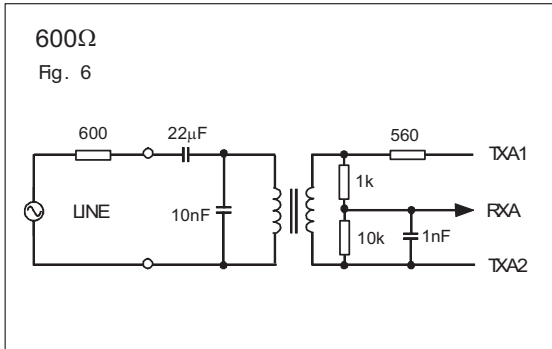

Insertion Loss (Line to RXA): 2.8dB @ 2kHz
 Frequency Response : ±0.2dB 30Hz – 10kHz
 Return Loss: 20dB 200Hz – 4kHz
 Transhybrid Loss: 30dB 50Hz – 10kHz

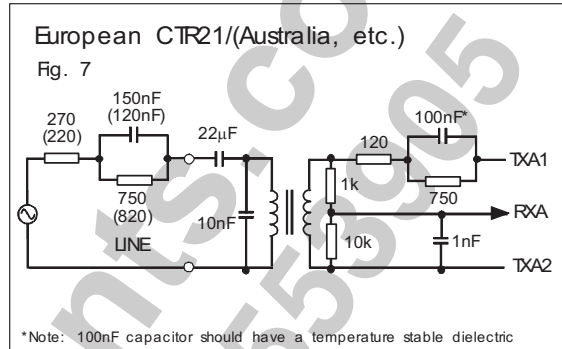

Insertion Loss (Line to RXA): 2.2dB @ 2kHz
 Frequency Response : ±0.5dB 50Hz – 4kHz
 Return Loss: 20dB 200Hz – 4kHz
 Transhybrid Loss: 18dB 200Hz – 4kHz

*Note: 100nF capacitor should have a temperature stable dielectric

600Ω Instrumentation

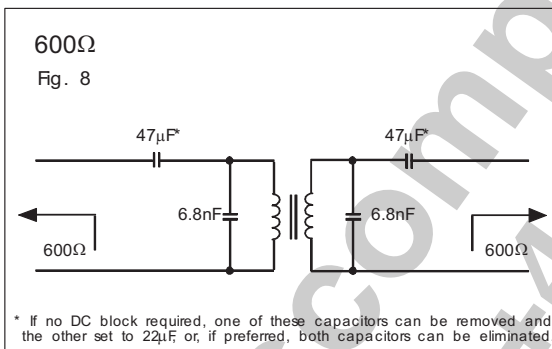

Insertion Loss: 1.5dB @ 2kHz
 Frequency Response : ±0.2dB 20Hz – 20kHz
 Return Loss: 16dB 20Hz – 20kHz

* If no DC block required, one of these capacitors can be removed and the other set to 22μF or, if preferred, both capacitors can be eliminated.

CERTIFICATION

Certified under the IEC CB scheme (Certificate DK-8570) to IEC 60950-1-2001, sub-clauses 1.5, 1.5.1, 1.5.2, 1.7.1, 2.9, 2.9.1, 2.9.2, 2.9.3, 2.10, 2.10.1, 2.10.2, 2.10.3, 2.10.3.1, 2.10.3.3, 2.10.4, 2.10.5, 2.10.5.1, 2.10.5.2, 2.10.5.4, 4.7, 4.7.1 (classV-1), 4.7.3, 4.7.3.1, 4.7.3.4, 5.2, 5.2.1, 5.2.2, 6.1.2.1 (Finland, Norway, Sweden national deviations) for a maximum working voltage of 250Vrms, nominal mains supply voltage not exceeding 300Vrms and a maximum operating temperature of 70°C in Pollution Degree 2 environments.

Certified to EN 60950-1:2001 (Demko Certificate 140243-01).

Recognized under the Component Recognition Program of Underwriters Laboratories Inc. to US and Canadian requirements CAN/CSA C22.2 No. 60950-1-03/UL60950-1, First Edition, based on IEC 60950-1, First Edition, maximum working voltage 180Vrms (creepage), 420V peak (clearance), Pollution Degree 2, supplementary insulation.

UL File number E203175.

Additionally, Profec Technologies certifies all transformers as providing voltage isolation of 2.12kVrms, 3kV DC minimum. All shipments are supported by a certificate of conformity to current applicable safety standards.

SAFETY

Constructed in accordance with IEC 60950-1, EN 60950-1, and UL 60950-1, supplementary insulation, 250Vrms maximum working voltage, flammability class V-0.

There are no special installation requirements (beyond attending to usual PCB track separations) since the integral cover provides supplementary insulation from its external faces to internal core and windings.

Patented

ENVIRONMENTAL TESTING

Reliability testing to IEC 68

Tested to clauses of IEC 68 and compliant with all functional and safety requirements following exposure as follows:

Test description	IEC 68 reference	Test details	Result
Robustness of terminations	68-2-21 Test Ua ₁ 68-2-21 Test Ua ₂	Tensile 5N pull Thrust 1N push	No impairment No pin detachment or distortion
Solderability	68-2-20 Test Ta Method 1	Solder bath 235°C 2s	No impairment Finish smooth, bright and even
Resistance to soldering heat	68-2-20 Test Tb Method 1A 68-2-20 Test Tb Method 2	Solder bath 260°C 10s Soldering iron 350°C 5s	
Vibration	68-2-6 Test Fc	Sweep 10-55-10Hz in 1 minute Amplitude 1.5mm pk-pk Duration 2h per axis, 3 axes	No impairment
Shock	68-2-27 Test Ea	Peak acceleration 1000m/s ² Duration of pulse 6ms 3 shocks each direction on 3 axes	No impairment
Cold	68-2-1 Test Ab	-25°C 16h Recovery to ambient 1-2h	No impairment
Dry heat	68-2-2 Test Bb	125°C 16h Recovery to ambient 1-2h	No impairment
Damp heat	68-2-3 Test Ca	40°C 4 days, RH 93% Recovery to ambient 1-2h	No impairment
Change of temperature	68-2-14 Test Na	T _A -25°C T _B +85°C t ₁ 30 min 2 min ≤ t ₂ ≤ 3 min Recovery to ambient 1-2h 5 cycles	No impairment

Combined Environmental Reliability Testing (CERT)

Components step stressed at increasing levels of severity using combined stresses to detect potential weaknesses.

Results are shown for highest levels of stress tested. Compliant with all functional and safety tests following exposure as follows:

Test description	Test details	Duration	Result
Storage Test	Thermal cycling -30°C to +100°C at 11°C/min 6mm pk 2-9Hz at 1 octave/min 20m/s ² 9-200Hz	20 mins per plane	No impairment
Transportation Test	Thermal cycling -65°C to +80°C Random vibration 10-200Hz and 200-2000Hz at 57m/s ² RMS	2 hours per plane	No impairment

CONSTRUCTION

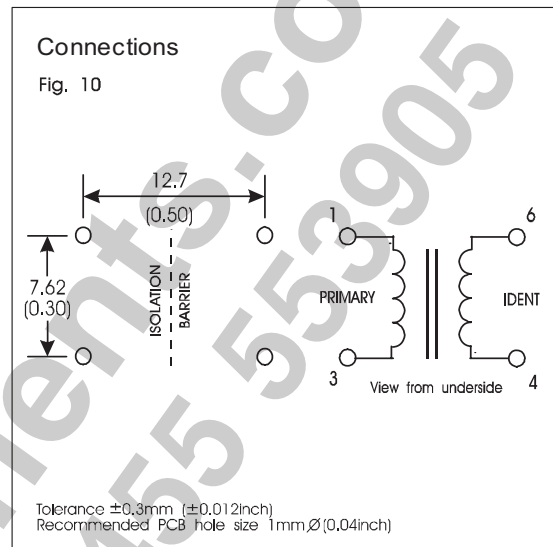
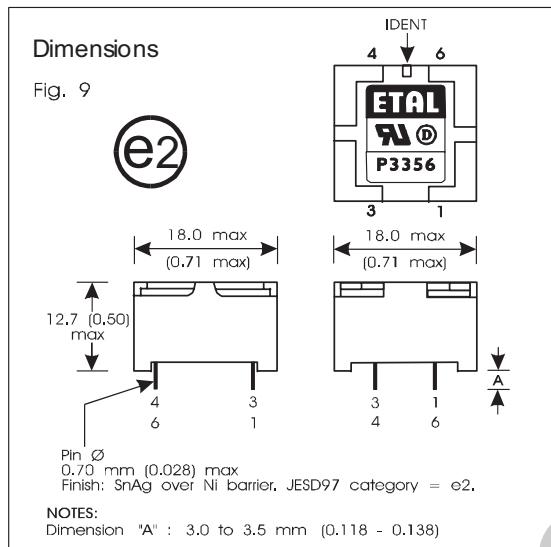

Dimensions shown are in millimetres (inches).
Geometric centres of outline and pin grid coincide within a tolerance circle of 0.6mm \varnothing .
Windings may be used interchangeably as primary or secondary.
Total weight typically 6.3g.

ABSOLUTE MAXIMUM RATINGS

(Ratings of components independent of circuit).

Short term isolation voltage (1s)	2.12kVrms, 3.0 kVDC
DC current	100 μ A
Storage temperature	-40°C to +85°C
Lead temperature, 10s	260°C

INTELLECTUAL PROPERTY RIGHTS

ETAL and P3356 are Trade Marks of Profec Technologies Ltd.
The Trade Mark ETAL is registered at the UK Trade Marks Registry.

Profec Technologies Ltd. is the owner of the design right under the Copyright Designs and Patents Act 1988 and no rights or licences are hereby granted or implied to any third party.

British Patent No. 2333646.
USA Patent Nos. 6, 344, 787; 6,690,254
European Patent No. 1082734
China Patent No. ZL 99806739.3
UK Registered Design No. 2077360.
French Registered Design No. 991512.
United States Registered Design 426, 815.
Mexico Registered Design 12143
Other patents and registered designs pending.

© 1998 - 2005 Profec Technologies Ltd.
Reproduction prohibited.



ISO 9001
FM 25326

ETAL Group Oy, Kuormatie 14, FIN-03101, Nummela
Telephone: +358 (0)20 7500 330 Fax: +358 (0)20 7500 333
Website: www.etalgroup.com Email: etalgroup@egruppen.com